

Large Current External FET Controller Type Switching Regulator

Single-output High-frequency Step-down Switching Regulator(Controller type)

BD9845FV

●Overview

BD9845FV is an IC containing a circuit of switching regulator controller by pulse width modulation system.

This circuit can be used for step-down DC/DC converter operation.

In addition, the package is designed compact, and is optimum for compact power supply for many kinds of equipment.

●Feature

- 1) High voltage resistance input ($V_{cc}=35V$)
- 2) FET driver circuit is contained (step-down circuit 1 output).
- 3) Error amplifier reference voltage ($1.0V\pm 1\%$) and REG output circuit (2.5V) are contained.
- 4) Overcurrent detection circuit is contained.
- 5) Soft start and pause period can be adjusted.
- 6) Three modes of standby, master, and slave can be switched. ($i_{ccs} = 0 \mu A$ typ in standby mode.)
- 7) ON/OFF control is enabled independently for each channel. (DT terminal)

●Application

LCD, PDP, PC, AV, Printer, DVD, Projector TV, Fax, Copy machine, Measuring instrument, etc.

●Operating condition ($T_a=25^\circ C$)

Item	Symbol	Range	Unit
Supply voltage	V_{cc}	3.6 to 35	V
Output terminal voltage	OUT	C5V – V_{cc}	V
Timing capacity	CCT	47 to 3000	pF
Oscillation frequency	F_{osc}	100 to 1500	kHz
STB input voltage	VSTB	0 to V_{cc}	V
SEL input voltage	VSELTB	0 to V_{cc}	V

●Absolute maximum rating

Item	Symbol	Rating	Unit
Supply voltage	V_{cc}	36	V
Permissible loss	P_d	500 *1	mW
OUT terminal voltage resistance	OUT	$V_{cc}-7V$ to V_{cc}	V
C5V terminal voltage resistance	C5V	$V_{cc}-7V$ to V_{cc}	V
Operation temperature range	T_{opr}	-40 to +85	$^\circ C$
Storage temperature range	T_{stg}	-55 to +150	$^\circ C$
Joint temperature	T_{jmax}	150	$^\circ C$

*1 When glass epoxy board 70.0 mm × 70.0 mm × 1.6 mm is installed onboard. Reduced by 4.0 mW/C above $T_a=25^\circ C$.

● Electric characteristics (Ta=25°C, VCC=6V unless otherwise specified)

Item	Symbol	Standard value			Unit	Condition
		Minimum	Standard	Maximum		
[VREF output unit]						
Output voltage	VREF	2.450	2.500	2.550	V	Io=0.1 mA
Input stability	Line reg.	—	1	10	mV	Vcc=3.6 V→35 V
Load stability	Load reg.	—	2	10	mV	Io=0.1 mA→2 mA
Current capacity	IOMAX	2	13	—	mA	VREF=(typ.) * 0.95
[Triangular wave oscillator]						
Oscillation frequency	FOSC	95	106	117	kHz	CCP=1800 pF
Frequency fluctuation	FDV	—	0	1	%	Vcc=3.6 V→35 V
[Soft start unit]						
SS source current	ISSSO	1.4	2	2.6	μA	SS=0.5 V
SS sink current	ISSSI	5	12	—	mA	SS=0.5 V
[Pause period adjusting circuit]						
DT input bias current	IDT	—	0.1	1	μA	DT=1.75 V
DT sink current	IDTSI	1	3.3	—	mA	DT=1.75 V, (OCP+)-(OCP-)=0.5 V
[Low input malfunction preventing circuit]						
Threshold voltage	VUTH	3.0	3.2	3.4	V	Vcc start detection
Hysteresis	VUHYS	—	0.15	0.25	V	
[Error amplifier]						
Non-inverting input reference voltage	VINV	0.99	1	1.01	V	INV=FB
Reference voltage supply fluctuation	dVinV	—	1	6	mV	Vcc=3.6 V→35 V
INV input bias current	IIB	—	0	1	μA	INV=1 V
Open gain	AV	65	85	—	dB	
Max output voltage	VFBH	2.30	—	VREF	V	
Min output voltage	VFBL	—	0.6	1.3	V	
Output sink current	IFBSI	0.5	1.5	—	mA	FB=1.25 V, INV=1.5 V
Output source current	IFBSO	50	105	—	μA	FB=1.25 V, INV=0.5 V
[PWM comparator]						
Input threshold voltage (fosc=100kHz)	Vt0	1.4	1.5	1.6	V	On duty 0%
	Vt100	1.9	2	2.1	V	On duty 100%
[Output unit]						
Output ON resistance H	RONH	—	4.0	10	Ω	RONH=(VCC-OUT)/Iout, Iout=0.1 A
Output ON resistance L	RONL	—	3.3	10	Ω	RONL=(OUT-C5V)/Iout, Iout=0.1 A
C5V clamp voltage	VCLMP	4.5	5	5.5	V	VCLMP=VCC-C5V, VCC > 7 V
[Overcurrent protection circuit]						
Overcurrent detection threshold voltage	VOCPTH	0.04	0.05	0.06	V	Voltage between (OCP+) and (OCP-)
OCP-input bias current	IOCP-	—	0.1	10	μA	OCP+=VCC, OCP-=VCC-0.5 V
Overcurrent detection delay time	tdocpth	—	200	400	nS	OCP-=VCC→VCC-0.2 V
Overcurrent detection minimum retention time	tdocpre	0.8	1.6	—	mS	OCP-=VCC-0.2 V→VCC

[Standby changeover unit]						
STB flow-in current	ISTB	-	55	100	μA	STB=6V
Standby mode setting range	VSTBL	0	-	0.5	V	
Active (master) mode setting range	VSTBH	3.0	-	VCC	V	
SEL flow-in current	ISEL	-	15	30	μA	SEL=2.5V
Master mode setting range	VSELL	0	-	0.5	V	
Slave mode setting range	VSELH	2.0	-	VCC	V	
[Device overall]						
Standby current	ICCS	-	0	1	μA	STB=0 V
Average power consumption	ICCA	1	2.4	4	mA	INV=0 V, FB=H, DT=1.75 V

* Radiation resistance design is not applied.

● Reference data

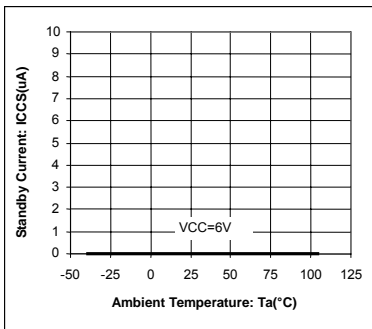

Fig.1 Standby current temperature characteristics

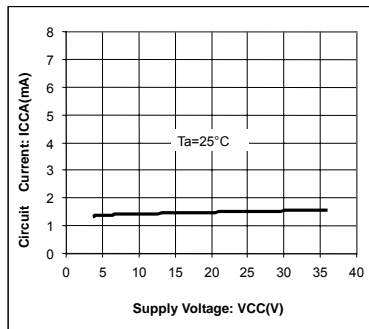

Fig.2 Circuit current in operation

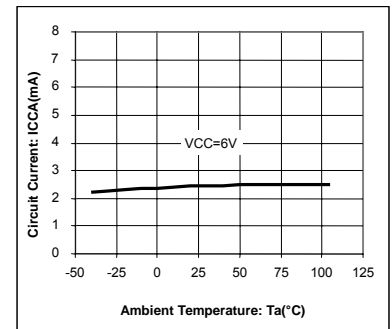

Fig.3 Circuit current temperature characteristics in operation

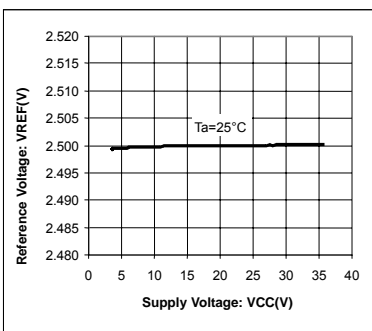

Fig.4 VREF supply voltage characteristics

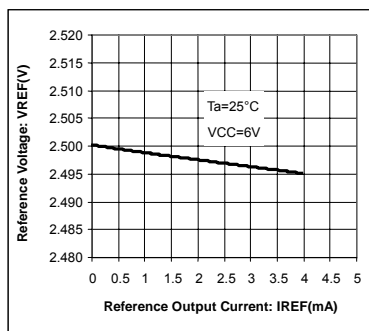

Fig.5 VREF current capability characteristics

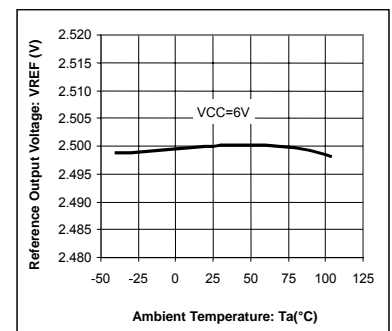

Fig.6 VREF temperature characteristics

● Reference data

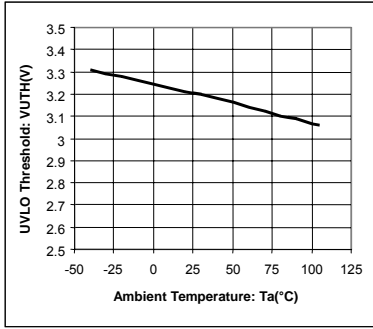

Fig.7 UVLO threshold temperature characteristics

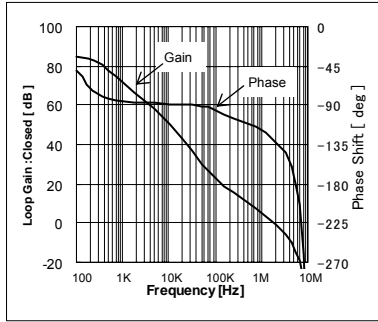

Fig.8 Error amplifier I/O characteristics

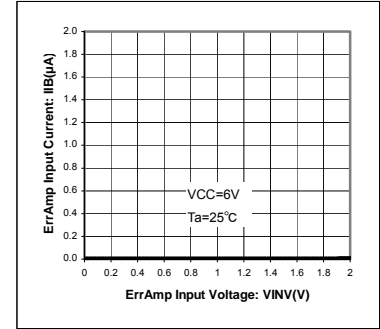

Fig.9 Error amplifier input current characteristics

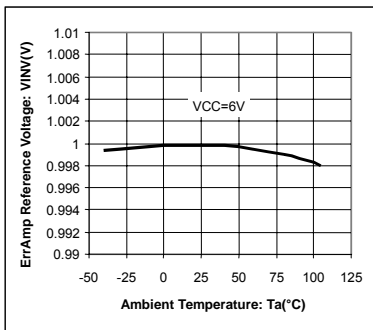

Fig.10 Error amplifier reference voltage temperature characteristics

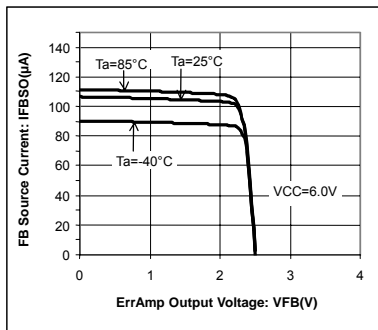

Fig.11 FB output source current characteristics

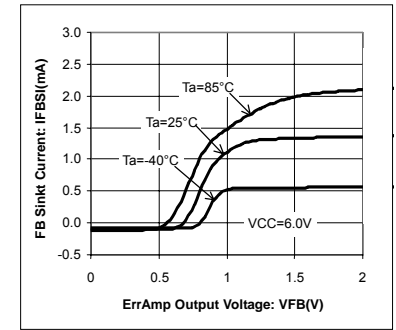

Fig.12 FB output sink current characteristics

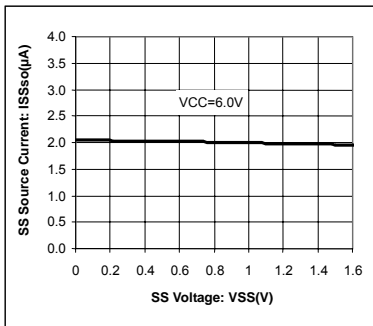

Fig.13 SS source current characteristics

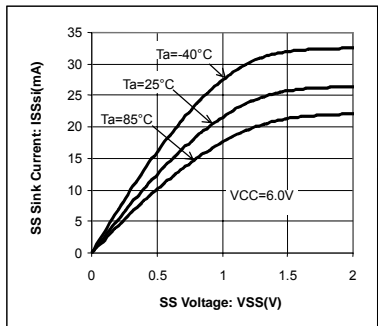

Fig.14 SS sink current characteristics

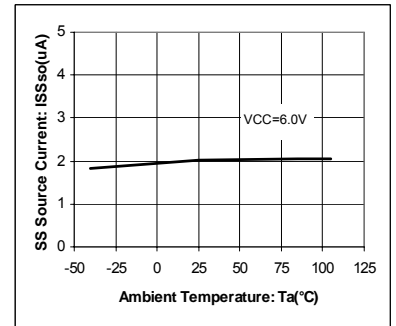

Fig.15 SS source current temperature characteristics

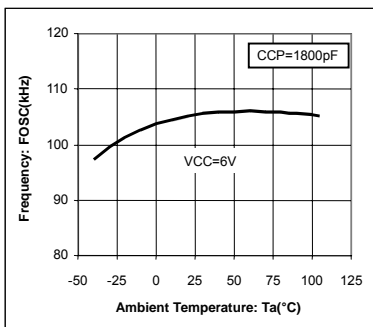

Fig.16 Oscillation frequency temperature characteristics

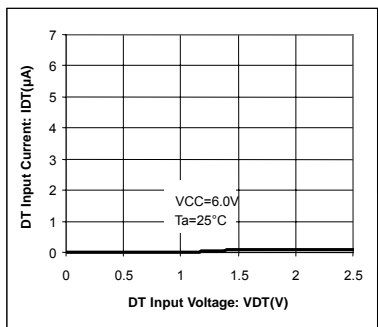

Fig.17 DT bias current characteristics

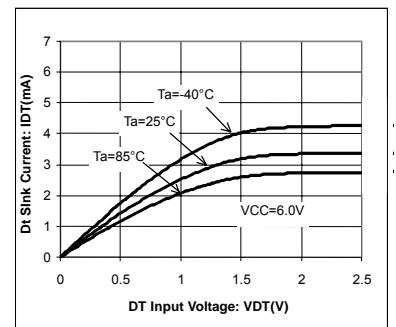

Fig.18 DT sink current characteristics

● Reference data

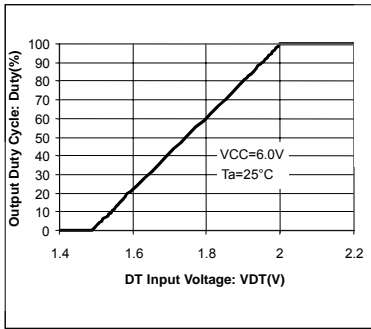

Fig.19 Output Duty-VDT characteristics (100kHz)

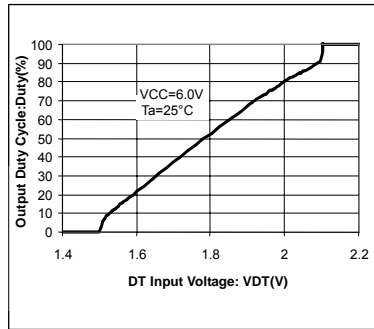

Fig.20 Output Duty-VDT characteristics (1.5MHz)

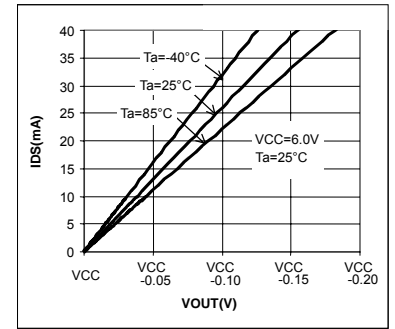

Fig.21 Output ON resistance H (RONH)

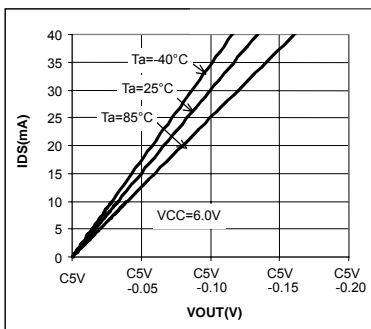

Fig.22 Output ON resistance L (RONL)

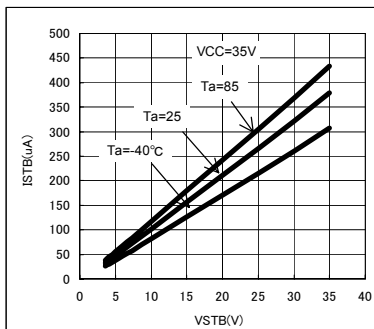

Fig.23 STB flow-in current

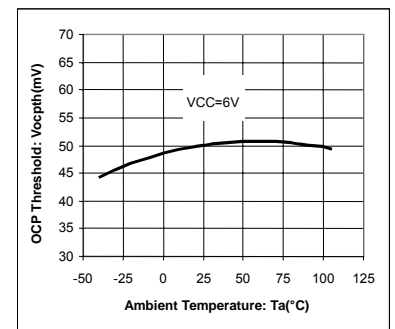

Fig.24 Overcurrent detection voltage temperature characteristics

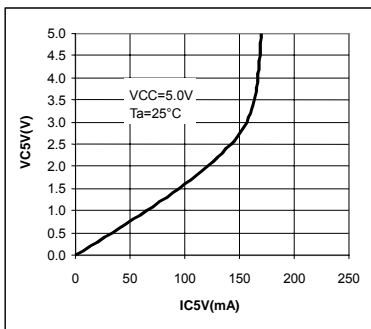

Fig.25 C5V saturation voltage

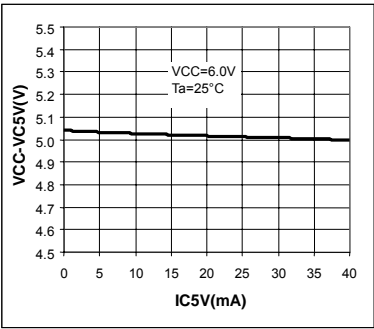

Fig.26 C5V load regulation

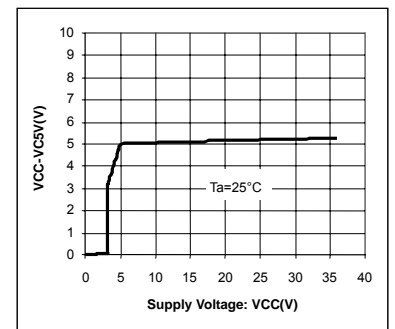

Fig.27 C5V line regulation

●Block diagram/Pin layout

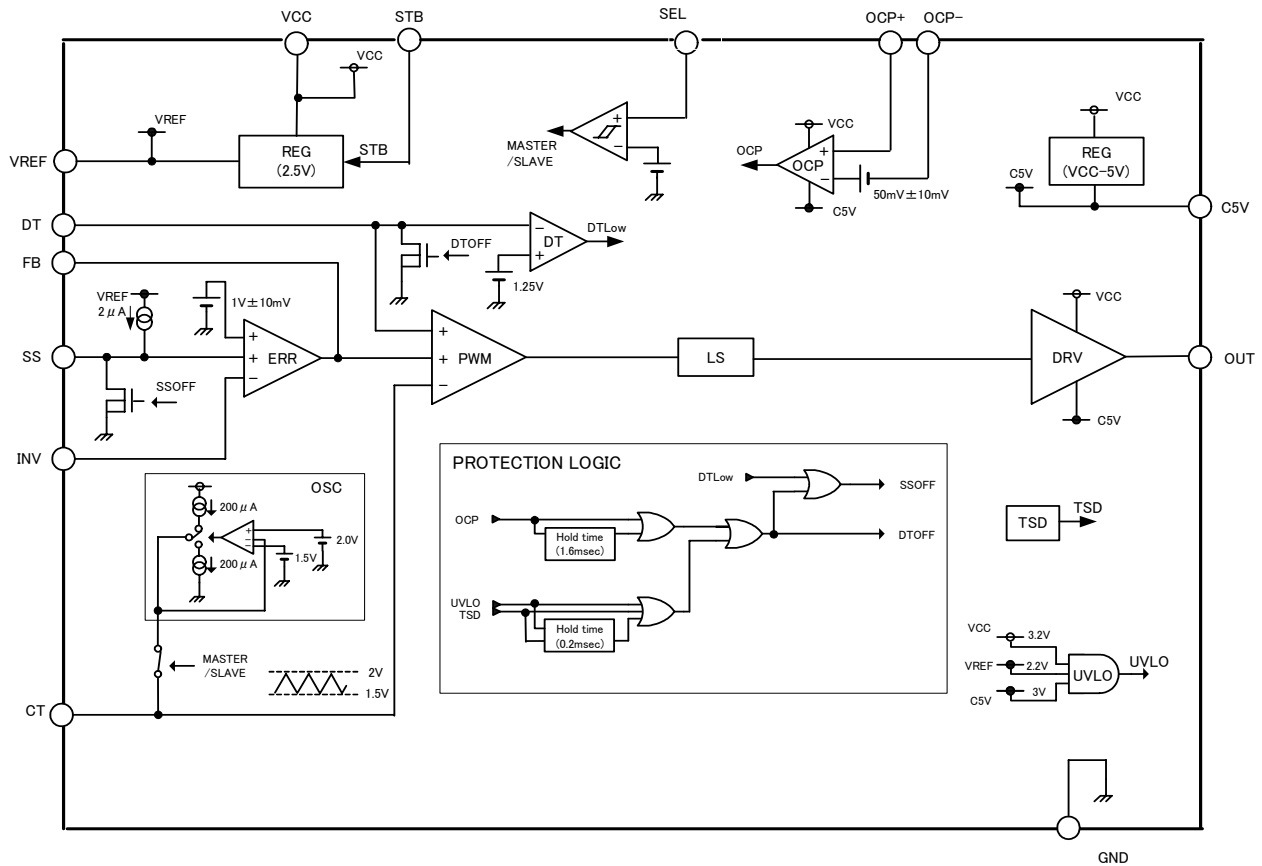

Fig.28 Block diagram

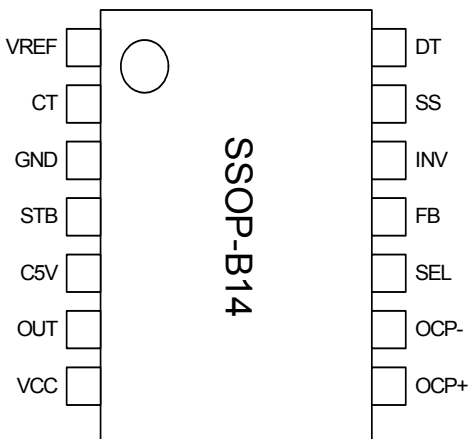

Fig.29 Pin layout

Terminal number	Terminal name	Function
1	VREF	Reference voltage (2.5V) output terminal
2	CT	Timing capacity external terminal
3	GND	GROUND
4	STB	Standby mode setting terminal
5	C5V	Output L side voltage (Vcc-5V)
6	OUT	Output
7	Vcc	Power terminal
8	OCP+	Output Overcurrent detector + Input terminal
9	OCP-	Output Overcurrent detector - Input terminal
10	SEL	Master/Slave mode setting terminal
11	FB	Output Error amplifier output terminal
12	INV	Output Error amplifier - input terminal
13	SS	Output Soft start time setting terminal
14	DT	Output Dead time setting terminal

● Operation description of each block and function

1) REG (reference voltage unit)

As for REG (2.5V), reference voltage (2.5V) stabilized better than supply voltage input to VCC terminal is supplied as an operation voltage of IC internal circuit, as well as output outside through VREF terminal. Insert a capacitor of 1uF to VREF terminal.

As for REG (VCC-5V), voltage of VCC-5V is supplied as power supply (LDO) of driver circuit (DRV) of OUT terminal, as well as output outside through C5V terminal. Insert a capacitor of 1uF to VCC terminal of C5V terminal.

2) ERR Amp (error amplifier)

In step-down application, inverting input INV of error amplifier detects output voltage by sending back feedback current from final output stage (on load side) of switching regulator. R1 and R2 connected to this input terminal are resistor for setting output voltage. Non-inverting input of amplifier is a reference input of error amplifier itself by adding reference voltage (1.0V) inside IC.

Rf and Cf connected between FB, which is output from error amplifier, and INV are for feedback of error amplifier, and allows setting of loop gain.

FB is connected to PWM Comp and supplied as non-inverting input.

Setting of output voltage (Vo) is as follows:

$$V_o = \frac{R1+R2}{R2} \times 1.0V$$

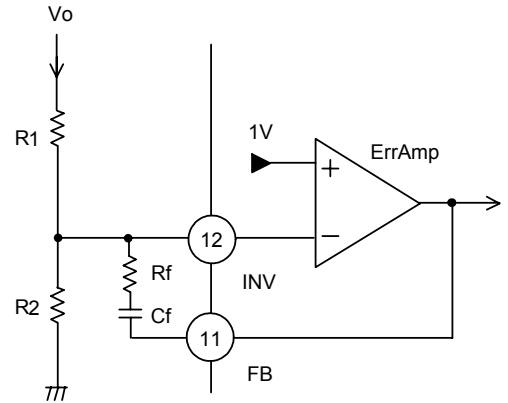

Fig.30

3) OSC (triangular wave oscillating unit)

Generates triangular wave for inputting to PWM Comp.

First, timing capacitor C_{CT} connected between CT terminal and GND is charged by constant current (200 uA) generated inside IC. When CT voltage reaches 2.0 V typ, the comparator is switched, and then C_{CT} is discharged by constant current (200 uA). Then, when CT voltage reaches 1.5V, the comparator is switched again, and C_{CT} is charged again. This repetition generates triangular wave.

Oscillation frequency is determined by externally mounted C_{CT} through theoretical formula below:

$$f_{osc} \approx \frac{I_{CT}}{2 \cdot C_{CT} \cdot \Delta V_{osc}}$$

ICT: CT sink/source current 200 uA typ
 ΔV_{osc} : Triangular wave amplifying voltage = (V_{t0}-V_{t100})=0.50 V typ.

Here, error from theoretical formula is caused by delay of internal circuit at a high frequency. See the graph in Fig 31 for setting.

This triangular wave can be taken out through CT terminal. It is also possible to input the oscillator externally by switching to slave mode described later. Waveform input here in principle must be triangular wave of V_{peak} = (1.5V ↔ 2.0V) equivalent to internal oscillation circuit.

External input voltage range

$$V_{CT}: 1.4 V < V_{CT} < 2.3 V$$

Standard external C_{CT} range

$$C_{CT}: \text{MIN.}47 \text{ pF} - \text{MAX.}3000 \text{ pF}$$

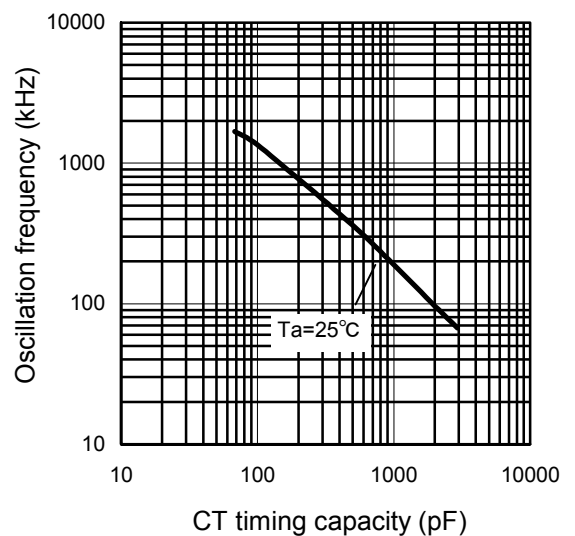

Fig.31

4) Soft start (soft start function)

It is possible to provide SS terminal (13pin) with soft start function by connecting C_{SS} as shown on the right.

Soft start time T_{SS} is shown by the formula below:

$$T_{SS} = C_{SS} \cdot \frac{V_{inv}}{I_{SSO}}$$

C_{SS} : SS terminal connection capacity
 V_{inv} : Error amplifier reference voltage (1V typ)
 I_{SSO} : SS source current (2uA typ)

(Ex) When C_{SS} = 0.01 uF

$$T_{SS} = \frac{0.01 \times 10^{-6} \times 1}{2 \times 10^{-6}} = 5 \text{ [msec]}$$

In order to function soft start, time must be set longer enough than start time of power supply and STB.

It is also possible to provide function of soft start by connecting the resistor (R1/R2) and capacitor (C_{DT}) to DT terminal (14pin) as shown on the right.

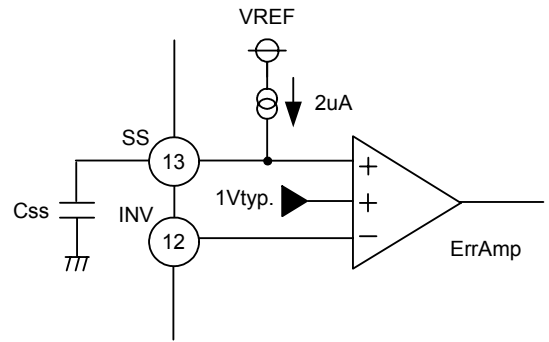

Fig.32

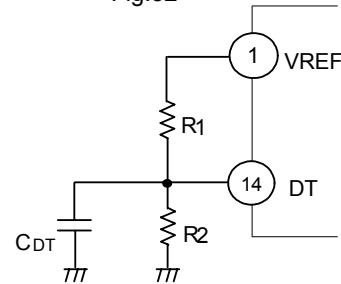

Fig.33

5) PWM Comp - DEAD TIME (Pause period adjusting circuit - dead time)

Dead time can be set by applying voltage dividing resistance between VREF and GND to DT terminal.

PWM Comp compares the input dead time voltage (DT terminal voltage) and error voltage from Err Amp (FB terminal voltage) with triangular wave, and turns off and on the output. When dead time voltage < error voltage, duty of output is determined by dead time voltage. (When dead time setting is not used, pull up DT terminal to VREF terminal with resistor approx 10 k ohms.)

Dead time voltage V_{DT} in Fig 32 is shown by the formula below:

$$V_{DT} = V_{REF} \cdot \frac{R2}{R1+R2}$$

Relation between V_{DT} and Duty [See the graph on the right.]

	Duty 100%			Duty 0%		
	min	typ	max	min	typ	max
When f = 100kHz	1.9	2.0	2.1	1.4	1.5	1.6
When f = 1.5MHz	1.95	2.1	2.25	1.35	1.5	1.65

[Unit : V]

Be careful when oscillation frequency is high, upper/lower limit of triangular wave (V_{t100}/V_{t0}) is shifted by delay time of comparator to directions expanding amplitude.

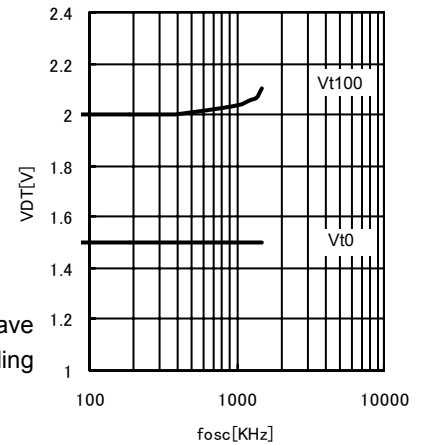

Fig.34

6) OCP Comp (overcurrent detection circuit)

This function provides protection by forcibly turning off the output when abnormal overcurrent flows due to shorting of output, etc. When voltage between terminal OCP+(8pin)/OCP-(9pin) monitoring the current with sense resistor exceeds overcurrent detection voltage (50 mV typ), it is determined as overcurrent condition, and switching operation is stopped immediately by setting OUT to "H" and DT,SS (and FB) to "L".

It is automatically recovered when voltage between terminal OCP+/OCP- is below overcurrent detection voltage.

In addition, although hysteresis, etc. are not set here, minimum detection retention time (1.6ms typ) is set for suppressing the heating of FET, etc. (See the timing chart.)

When the overcurrent detection circuit is not used, short-circuit both terminal OCP+/OCP- to VCC pin.

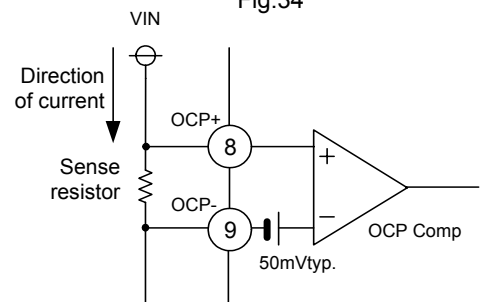

Fig.35

7) STB /SEL(Standby/Master/Slave function)

Standby mode and normal mode can be switched by STB terminal (4pin).

1. When STB<0.5V, standby mode is set.
Out put stop (OUT=H) and REG also stops. Circuit current is also $I_{sc} = 0 \mu A$ here.
2. When STB>3.0V, normal operation mode is set.
All circuits operate. Use the controller normally in this range.

Master mode and slave mode can be switched by SEL terminal (10pin).

1. When SEL<0.5V, master mode is set.
All circuits operate.
2. When SEL>0.5V, slave mode is set.
Operation status is set , but OSC block alone is stopped, CT terminal is High-Z here, and triangular wave is not output.(PWM circuit and protection circuit perform the same operation as usual.) Therefore, if the controller is used in this more without using master IC, triangular wave is not emitted, operation is unstable, and normal output cannot be obtained. Be careful.

8) OUT (Output: External FET gate drive)

OUT terminal (6pin) is capable of directly driving the gate of external (PchMOS) FET. Amplitude of output is restricted between V_{cc} and C5V ($V_{cc}-5V$), and is not restricted by voltage resistance of gate by input voltage, which allows broad selection of FET.

However, for precaution when selecting FET, there is a restriction that input capacity of gate is determined by current capability of C5V and permissible loss of IC, therefore refer to the permissible range in the graph on the right when determining FET.

9) Protection (other protection functions)

This IC is equipped with low input malfunction prevention circuit (UVLO) and abnormal temperature protection circuit (TSD) in addition to overcurrent detection circuit (OCP).

Low input malfunction prevention circuit is for preventing unstable output when input voltage is low.

Three positions of V_{cc} (3.2V), V_{REF} (2.35V), and C5V($V_{cc}-3V$) are monitored, and output is made only when all are canceled. (See the timing chart.)

Abnormal temperature protection circuit is for protecting IC chip from destruction for preventing runaway when abnormal heating is caused on IC exceeding rated temperature. (It does not operate normally.)

Apply a design with full margin allowed for heating in consideration of permissible loss.

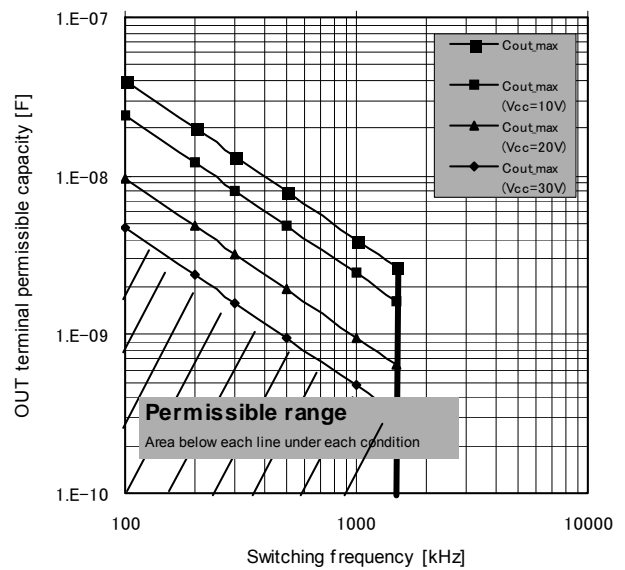
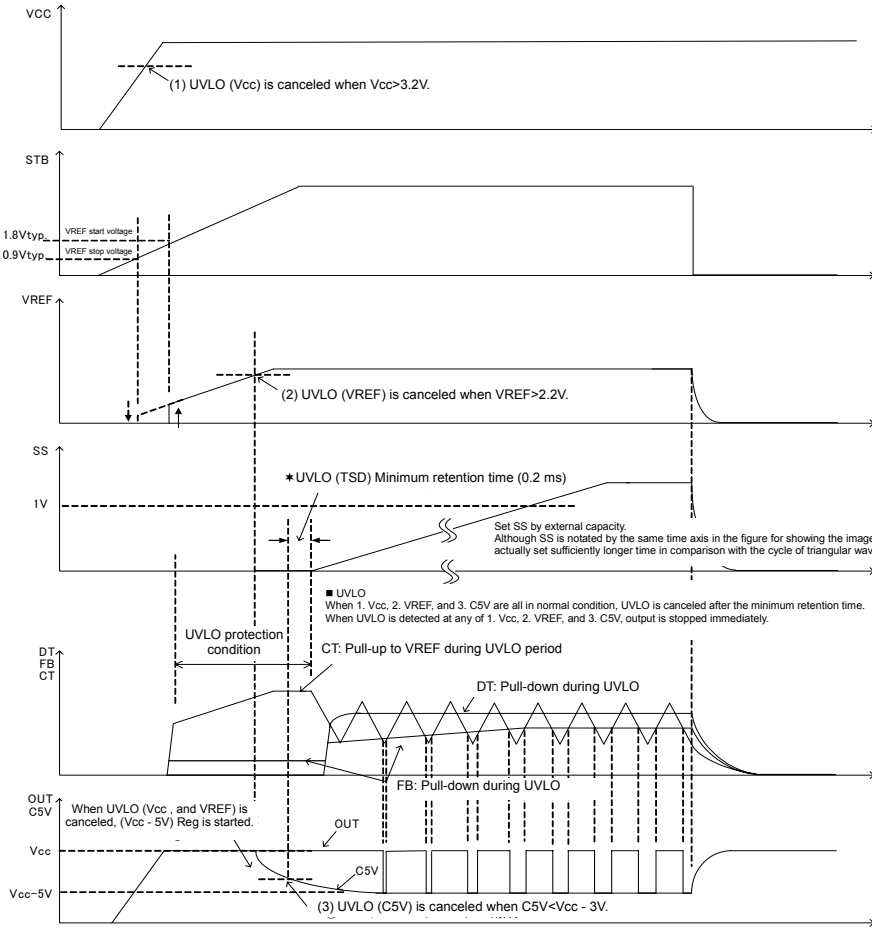

Fig.36

● Timing chart

◎ Starting characteristics (UVLO cancel) and standby operation



UVLO voltage [unit: V]

Item	Minimum	Standard	Maximum
Threshold voltage (VCC)	3.0	3.2	3.4
Hysteresis	-	0.15	0.25
Threshold voltage (VREF)	2.0	2.2	2.4
Threshold voltage (C5V)	-	3.0	3.4

◎ Overcurrent detection (When output is shorted: Overcurrent detection and cancel are repeated at a specified time interval.)

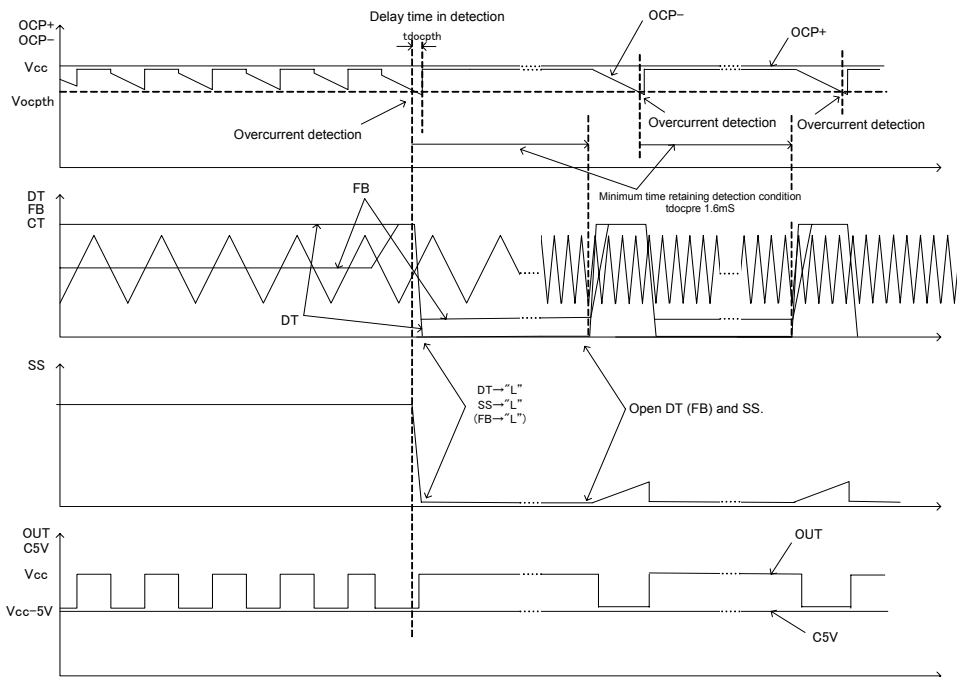

●Example of application circuit

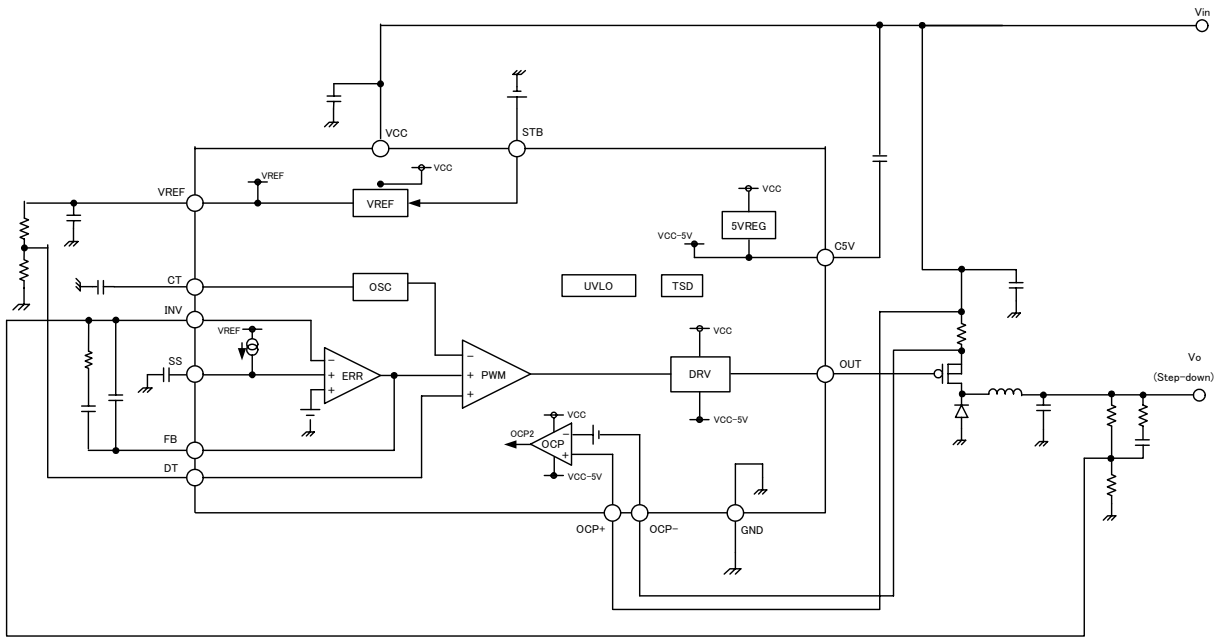

Fig.37

1) Setting of output unit coil (L) and capacitor (Co)

Set the coil and capacitor as follows in step-down application:

<Setting of L-value>

When load current gets heavy, the current flowing through the coil gets continuous, and the relation below is established:

$$L = \frac{T_{sw}}{\Delta I_L} \times \frac{(V_{in}-V_o) \times V_o}{V_{in}}$$

Vin: Input voltage

Tsw: 1/(switching frequency)

Delta IL: Ripple current of coil

Normally set Delta IL below 30% of the maximum output current (Iomax).

When L-value is made greater, ripple current (Delta IL) becomes smaller. In general, the greater the L-value is, the smaller the permissible current of coil gets, and when the current exceeds permissible current, the coil is saturated and L-value changes. Contact the coil manufacturer and check permissible current.

<Setting of output capacitor Co>

Select an output capacitor Co by ESR (equivalent serial resistance) property of capacitor.

Output ripple voltage (Delta Vo) is almost ESR of output capacitor, therefore,

$$\Delta V_o \cong \Delta I_L \times ESR \quad \text{ESR: Equivalent serial resistance of output capacitor Co}$$

The relation above is established.

Ripple component by output capacitor is small enough to be neglected in comparison with ripple component by ESR in many cases. As for Co value, it is recommended to use a sufficiently large capacitor with a capacity that satisfies ESR condition.

<Switching element>

Determine a switching element by peak current. Peak current Isw <peak> flowing through the switching element is equal to peak current flowing through the coil, therefore the equation below is established.

$$I_{sw} (\text{peak}) = I_o + \Delta I_L / 2$$

Select a switching element of permissible current having a sufficient margin over peak current calculated by the equation.

2) Example of overcurrent protection circuit

Insert a sense resistor between the source and VIN of output Pch-FET for detecting overcurrent as shown in the figure.

Refer to the formula below for determining a sense resistor and select permissible loss ensuring a margin.

$$R_{sense} = \frac{V_{ocpth}}{I_{ocp}} \quad \begin{array}{l} V_{ocpth} : \text{Overcurrent detection voltage (50 mV typ)} \\ I_{ocp} : \text{Overcurrent detection setting current} \end{array}$$

I_{ocp} is a peak current I_{sw} (peak) here, and the amperage for output load is an overcurrent setting amperage minus ripple current component ($\Delta I_L/2$), etc. (See the formula on P10.)

There is a time delay approx 200ns from detection until stop of output is made (pulse of approx 100 ns causes delay time but detection is made), and an error may be caused from the value above.

In addition, input to overcurrent detection unit is such a sensitive circuit, and wrong detection by noise may be possible. When wrong detection occurs, try to eliminate noise by the resistor R1 and R2 or capacitance C1, C2, C3, and C4 shown above.

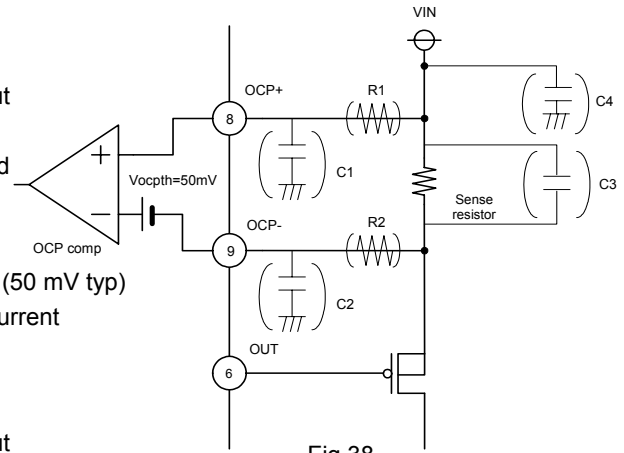

Fig.38

3) Example of output ON/OFF control circuit

When stopping the whole circuit, set STB terminal to "Low (STB<0.5V) to stop switching and reduce power consumption of IC to 0 microA (typ).

Also when switching ON and OFF for each channel, control is fixed to OFF by setting DT terminal of desired channel to "Low (DT<1.25V)". This control is independent for each channel, and when DT="L", SS terminal and FB terminal are also discharged, and soft start is enabled in restarting.

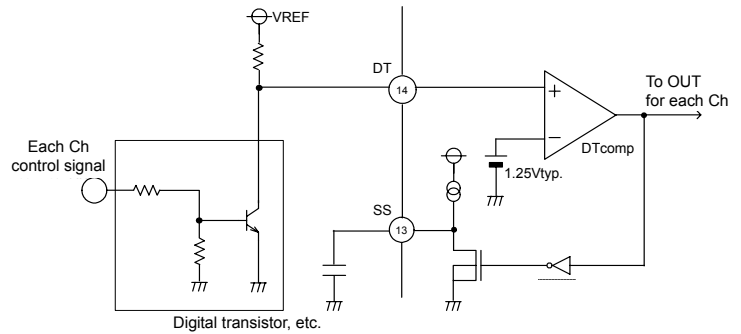

Fig.39

4) Example of master/slave (sync multi-ch output) operation circuit

This IC is set to slave mode by setting the input of STB terminal at $2.5V \pm 0.1V$, and multi-channel output is enabled with frequency synchronized. (Fig.40) However, CT terminal has high impedance in slave mode status, and triangular wave is generated by CT waveform of master mode IC. Therefore the example of master slave circuit below is recommended when starting and stopping in order to avoid malfunction by start/stop timing of master IC and slave IC. As for output, it is recommended to control ON/OFF reliably with DT terminal.

Also, oscillation frequency is determined by capacitor (C_{CT}) connected to CT. When the slave IC is large in number as well as oscillation frequency is high, parasitic capacity by board wiring in contact with CT cannot be ignored, and preset frequency may be drifted. Be careful.

Example of master/slave circuit configuration is shown below. If any other configuration is to be applied, inform our personnel in charge.

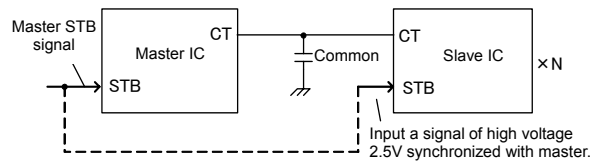

Fig.40

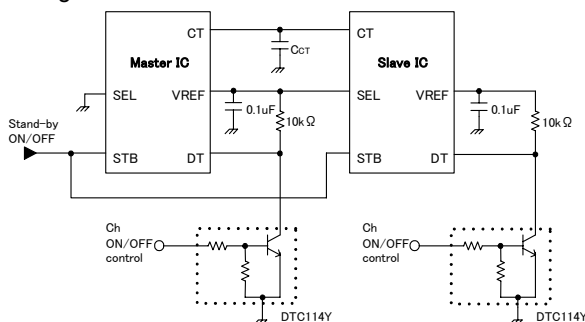

Fig 41. Example of master/slave

5) About board layout

In order to make full use of IC performance, fully investigate the items below in addition to general precautions.

- Each output of OCP+/OCP- is such a sensitive circuit. When wiring is routed around, it is easily subjected to noise. Try to make the wiring as short as possible.
- Switching of large current is likely to generate noise. Try to make the large current route (VIN, Rsense, FET, L, Di, and Cout) as thick and short as possible, and try to apply one-point grounding for GND. OUT terminal is also a switching line, and it must be wired along a distance as short as possible. (When multi-layer board is used, shielding by intermediate layer also seems to be effective.)
- C_{CT} and C_{VREF} are reference of all, and must be wired along the shortest distance to GND of IC stabilized to be protected against external influence.
- Also be careful not to allow common impedance to sense family GND.

(6) PIN processing of channel unused

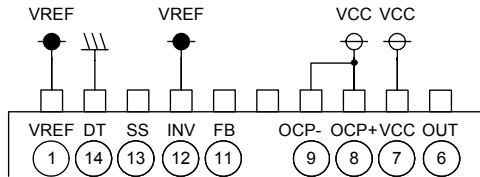

Fig.43

When only one channel is used, process unused channels as shown above.

● I/O equivalent circuit diagram

<p>2pin(CT)</p>	<p>14pin (DT)</p>	<p>13pin (SS)</p>	
<p>12pin (INV)</p>	<p>11pin (FB)</p>	<p>9pin (OCP-)</p>	
<p>5pin (C5V)</p>	<p>6pin (OUT)</p>	<p>8pin (OCP+)</p>	
<p>4pin (STB)</p>	<p>10pin (SEL)</p>	<p>1pin (VREF)</p>	<p>3pin (GND) , 7pin (VCC)</p>

● Precaution for use

1) About maximum absolute rating

When the maximum absolute rating of application voltage or operation voltage range is exceeded, it may lead to deterioration or rupture. It is impossible to forecast rupture in short mode or open mode. When a special mode is expected exceeding the maximum absolute rating, try to take a physical safety measure such as a fuse.

2) GND potential

Ensure that the potential of GND terminal is the minimum in any operation condition. Also ensure that no terminal except GND terminal has a voltage below GND voltage including actual transient phenomenon.

3) Thermal design

Allow a sufficient margin in thermal design in consideration of permissible loss (Pd) in actual use condition.

4) Shorting between terminals and wrong attachment

When attaching an IC to a set board, pay full attention to the direction of IC and dislocation. Wrong attachment may cause rupture of IC. In addition, when shorting is caused by foreign substance placed between outputs or between output and power supply-GND, rupture is also possible.

5) Operation in intense magnetic field

Use in intense magnetic field may result in malfunction. Be careful.

6) Inspection on set board

In inspection on set board, when a capacitor is connected to a terminal with low impedance, stress may be applied to IC, therefore be sure to discharge electricity in each process. Apply grounding to assembling process for a measure against static electricity, and take enough care in transport and storage. When connecting a jig in inspection process, be sure to turn off power before detaching IC.

7) About IC terminal input

This IC is a monolithic IC, and contains P⁺ isolation and P board for separating elements between each element. This P-layer and N-layer of each element form P-N junction, and many kinds of parasitic elements are constituted. (See Fig 43.)

For example, when resistor and transistor are connected with a terminal as shown below.

- P-N junction operates as a parasitic diode when GND > (Terminal A) for resistor, and when GND > (Terminal B) for transistor (NPN).
- In addition, when GND > (Terminal B) for transistor (NPN), parasitic NPN transistor is operated by N-layer of some other elements in the vicinity of parasitic diode mentioned above.

Parasitic element is inevitably generated by potential because of IC structure. Operation of parasitic element causes interference with circuit operation, and may lead to malfunction, and also may cause rupture. Therefore when applying a voltage lower than GND (P board) to I/O terminal, pay full attention to usage so that parasitic elements do not operate.

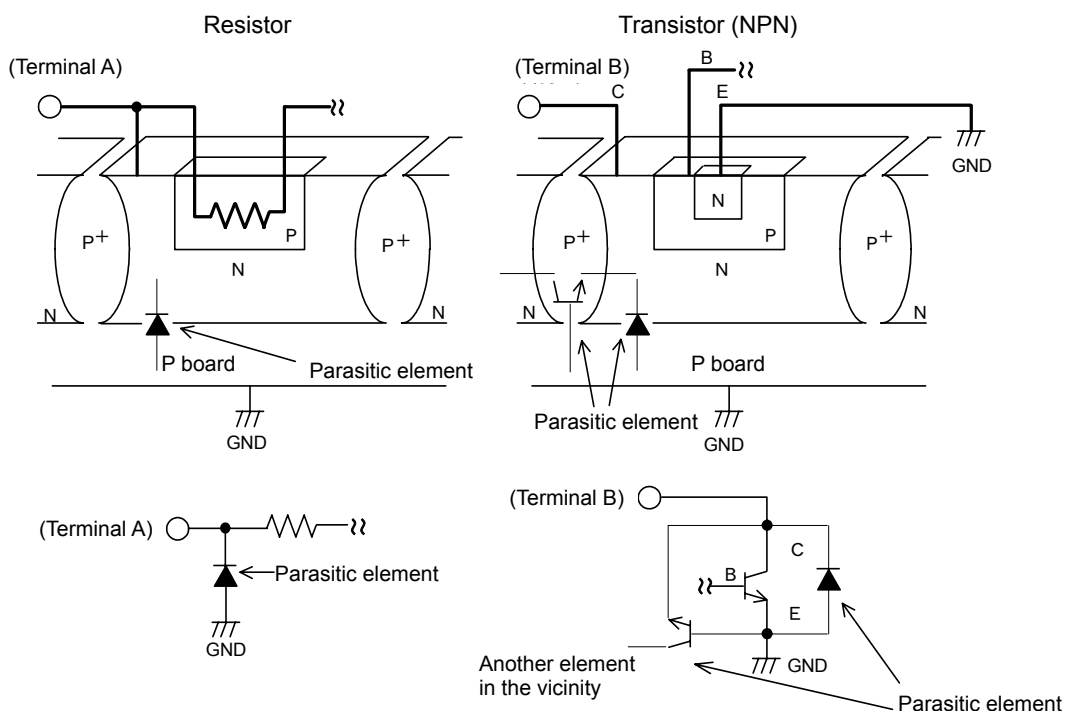
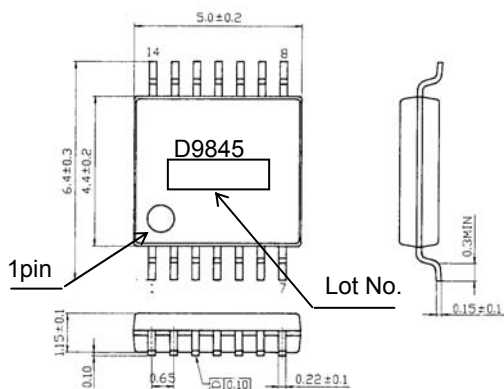

Fig.44

● Outer dimension view



SSOP-B14 [单位: mm]

● Order model name

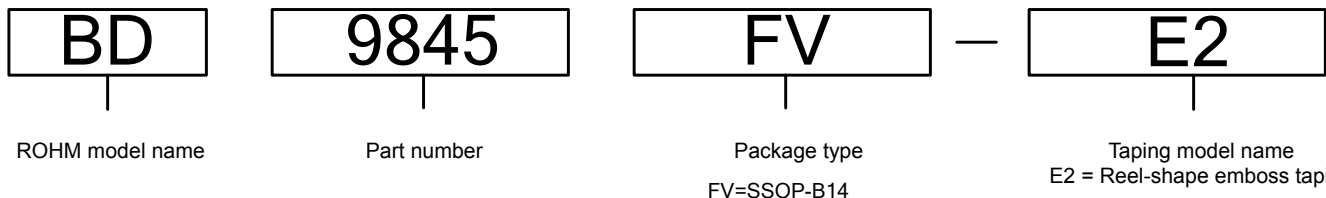

SSOP-B14

<p><Dimension></p> <p style="text-align: right;">(Unit:mm)</p>	<p><Tape and Reel information></p> <table border="1" style="width: 100%; border-collapse: collapse;"> <tr> <td style="width: 20%;">Tape</td> <td>Embossed carrier tape</td> </tr> <tr> <td>Quantity</td> <td>2500pcs</td> </tr> <tr> <td>Direction of feed</td> <td>E2 (The direction is the 1pin of product is at the upper left when you hold reel on the left hand and you pull out the tape on the right hand)</td> </tr> </table> <p style="text-align: center;">※When you order , please order in times the amount of package quantity.</p>	Tape	Embossed carrier tape	Quantity	2500pcs	Direction of feed	E2 (The direction is the 1pin of product is at the upper left when you hold reel on the left hand and you pull out the tape on the right hand)
Tape	Embossed carrier tape						
Quantity	2500pcs						
Direction of feed	E2 (The direction is the 1pin of product is at the upper left when you hold reel on the left hand and you pull out the tape on the right hand)						

- The contents described herein are correct as of September, 2008
- The contents described herein are subject to change without notice. For updates of the latest information, please contact and confirm with ROHM CO.,LTD.
- Any part of this application note must not be duplicated or copied without our permission.
- Application circuit diagrams and circuit constants contained herein are shown as examples of standard use and operation. Please pay careful attention to the peripheral conditions when designing circuits and deciding upon circuit constants in the set.
- Any data, including, but not limited to application circuit diagrams and information, described herein are intended only as illustrations of such devices and not as the specifications for such devices. ROHM CO.,LTD. disclaims any warranty that any use of such devices shall be free from infringement of any third party's intellectual property rights or other proprietary rights, and further, assumes no liability of whatsoever nature in the event of any such infringement, or arising from or connected with or related to the use of such devices.
- Upon the sale of any such devices, other than for buyer's right to use such devices itself, resell or otherwise dispose of the same, implied right or license to practice or commercially exploit any intellectual property rights or other proprietary rights owned or controlled by ROHM CO., LTD. is granted to any such buyer.
- The products described herein utilize silicon as the main material.
- The products described herein are not designed to be X ray proof.

The products listed in this catalog are designed to be used with ordinary electronic equipment or devices (such as audio visual equipment, office-automation equipment, communications devices, electrical appliances and electronic toys). Should you intend to use these products with equipment or devices which require an extremely high level of reliability and the malfunction of which would directly endanger human life (such as medical instruments, transportation equipment, aerospace machinery, nuclear-reactor controllers, fuel controllers and other safety devices), please be sure to consult with our sales representative in advance.

Contact us for further information about the products.

San Diego	TEL: +1-858-625-3630	FAX: +1-858-625-3670	Tianjin	TEL: +86-22-23029181	FAX: +86-22-23029183
Atlanta	TEL: +1-770-754-5972	FAX: +1-770-754-0691	Shanghai	TEL: +86-21-6279-2727	FAX: +86-21-6247-2066
Boston	TEL: +1-978-371-0382	FAX: +1-928-438-7164	Hangzhou	TEL: +86-571-87658072	FAX: +86-571-87658071
Chicago	TEL: +1-847-368-1006	FAX: +1-847-368-1008	Nanjing	TEL: +86-25-8689-0015	FAX: +86-25-8689-0393
Dallas	TEL: +1-469-287-5366	FAX: +1-469-362-7973	Ningbo	TEL: +86-574-87654201	FAX: +86-574-87654208
Denver	TEL: +1-303-708-0908	FAX: +1-303-708-0858	Qingdao	TEL: +86-532-5779-312	FAX: +86-532-5779-653
Detroit	TEL: +1-248-348-9920	FAX: +1-248-348-9942	Suzhou	TEL: +86-512-6807-1300	FAX: +86-512-6807-2300
Nashville	TEL: +1-615-620-6700	FAX: +1-615-620-6702	Wuxi	TEL: +86-510-82702693	FAX: +86-510-82702992
Mexico	TEL: +52-33-3123-2001	FAX: +52-33-3123-2002	Shenzhen	TEL: +86-755-8307-3008	FAX: +86-755-8307-3003
Düsseldorf	TEL: +49-2154-9210	FAX: +49-2154-921400	Dongguan	TEL: +86-769-8393-3320	FAX: +86-769-8398-4140
Munich	TEL: +49-8999-216168	FAX: +49-8999-216176	Fuzhou	TEL: +86-591-8801-8698	FAX: +86-591-8801-8690
Stuttgart	TEL: +49-711-7272-370	FAX: +49-711-7272-3720	Guangzhou	TEL: +86-20-3878-8100	FAX: +86-20-3825-5965
France	TEL: +33-1-5697-3060	FAX: +33-1-5697-3080	Huizhou	TEL: +86-752-205-1054	FAX: +86-752-205-1059
United Kingdom	TEL: +44-1-908-306700	FAX: +44-1-908-235788	Xiamen	TEL: +86-592-238-5705	FAX: +86-592-239-8380
Denmark	TEL: +45-3694-4739	FAX: +45-3694-4789	Zhuhai	TEL: +86-756-3232-480	FAX: +86-756-3232-460
Espoo	TEL: +358-9725-54491	FAX: +358-9-7255-4499	Hong Kong	TEL: +852-2-740-6262	FAX: +852-2-375-8971
Salo	TEL: +358-2-7332234	FAX: +358-2-7332237	Taipei	TEL: +886-2-2500-6956	FAX: +886-2-2503-2869
Oulu	TEL: +358-9-5372930	FAX: +358-8-5372931	Kaohsiung	TEL: +886-7-237-0881	FAX: +886-7-238-7332
Barcelona	TEL: +34-9375-24320	FAX: +34-9375-24410	Singapore	TEL: +65-6332-2322	FAX: +65-6332-5662
Hungary	TEL: +36-1-4719338	FAX: +36-1-4719339	Philippines	TEL: +63-2-807-6872	FAX: +63-2-809-1422
Poland	TEL: +48-22-5757213	FAX: +48-22-5757001	Thailand	TEL: +66-2-254-4890	FAX: +66-2-256-6334
Russia	TEL: +7-495-739-41-74	FAX: +7-495-739-41-74	Kuala Lumpur	TEL: +60-3-7958-8355	FAX: +60-3-7958-8377
Seoul	TEL: +82-2-8182-700	FAX: +82-2-8182-715	Penang	TEL: +60-4-2286453	FAX: +60-4-2286452
Masan	TEL: +82-55-240-6234	FAX: +82-55-240-6236	Kyoto	TEL: +81-75-365-1218	FAX: +81-75-365-1228
Dalian	TEL: +86-411-8230-8549	FAX: +86-411-8230-8537	Yokohama	TEL: +81-45-476-2290	FAX: +81-45-476-2295
Beijing	TEL: +86-10-8525-2483	FAX: +86-10-8525-2489			

Excellence in Electronics

ROHM

ROHM CO., LTD.

21 Saiin Mizosaki-cho, Ukyo-ku, Kyoto
615-8585, Japan
TEL: +81-75-311-2121 FAX: +81-75-315-0172
URL <http://www.rohm.com>

Published by
KTC LSI Development Headquarters
LSI Business Promotion Group

Notes

No copying or reproduction of this document, in part or in whole, is permitted without the consent of ROHM CO.,LTD.

The content specified herein is subject to change for improvement without notice.

The content specified herein is for the purpose of introducing ROHM's products (hereinafter "Products"). If you wish to use any such Product, please be sure to refer to the specifications, which can be obtained from ROHM upon request.

Examples of application circuits, circuit constants and any other information contained herein illustrate the standard usage and operations of the Products. The peripheral conditions must be taken into account when designing circuits for mass production.

Great care was taken in ensuring the accuracy of the information specified in this document. However, should you incur any damage arising from any inaccuracy or misprint of such information, ROHM shall bear no responsibility for such damage.

The technical information specified herein is intended only to show the typical functions of and examples of application circuits for the Products. ROHM does not grant you, explicitly or implicitly, any license to use or exercise intellectual property or other rights held by ROHM and other parties. ROHM shall bear no responsibility whatsoever for any dispute arising from the use of such technical information.

The Products specified in this document are intended to be used with general-use electronic equipment or devices (such as audio visual equipment, office-automation equipment, communication devices, electronic appliances and amusement devices).

The Products are not designed to be radiation tolerant.

While ROHM always makes efforts to enhance the quality and reliability of its Products, a Product may fail or malfunction for a variety of reasons.

Please be sure to implement in your equipment using the Products safety measures to guard against the possibility of physical injury, fire or any other damage caused in the event of the failure of any Product, such as derating, redundancy, fire control and fail-safe designs. ROHM shall bear no responsibility whatsoever for your use of any Product outside of the prescribed scope or not in accordance with the instruction manual.

The Products are not designed or manufactured to be used with any equipment, device or system which requires an extremely high level of reliability the failure or malfunction of which may result in a direct threat to human life or create a risk of human injury (such as a medical instrument, transportation equipment, aerospace machinery, nuclear-reactor controller, fuel-controller or other safety device). ROHM shall bear no responsibility in any way for use of any of the Products for the above special purposes. If a Product is intended to be used for any such special purpose, please contact a ROHM sales representative before purchasing.

If you intend to export or ship overseas any Product or technology specified herein that may be controlled under the Foreign Exchange and the Foreign Trade Law, you will be required to obtain a license or permit under the Law.

Thank you for your accessing to ROHM product informations.

More detail product informations and catalogs are available, please contact your nearest sales office.

ROHM Customer Support System

THE AMERICAS / EUROPE / ASIA / JAPAN

www.rohm.com

Contact us : webmaster@rohm.co.jp